

REV	DATE	DESCRIPTION	ECO	BY	C'H'K.
E	2020-06-05 09:37:00 EDT	NEW CAT ADDED 60245	53654	KV	NJ

CONDUCTORS ACCOMMODATED

I.P.S. PIPE		ROD		AWG		METRIC WIRE SIZE		CATALOG NUMBER	B	J	M	W	Y	"U" BOLT	TORQUE Lb*in [N*m]
NOMINAL DIAMETER (IN)	ACTUAL DIA. (IN) (MM)	NOMINAL DIAMETER (in)	ACTUAL DIAMETER (in) (mm)	MIN	MAX	MIN	MAX								
3"	3.500 [89]	3"	3.00 [76]	#4 SOL(.204 DIA)	2/0 STR(.416 DIA)	25mm ² STR[6.5]	50mm ² STR[9.3]	GD2026	1.50 [38]	3/8" [10]	2.75 [70]	4.81 [118]	3.38 [83]	258	240 [27.0]
3"	3.500 [89]	3"	3.00 [76]	2/0 SOL(.365 DIA)	250 Kcmil(.575 DIA)	70mm ² STR[10.9]	120mm ² STR[14.4]	GD2029	1.50 [38]	3/8" [10]	2.88 [73]	4.81 [118]	3.38 [83]	258	240 [27.0]
3"	3.500 [89]	3"	3.00 [76]	300 kcmil(.630 DIA)	500 Kcmil(.814 DIA)	185mm ² STR[17.8]	240mm ² STR[20.3]	GD2034	1.56 [40]	1/2" [13]	2.31 [59]	5.31 [130]	4.00 [98]	282	480 [54.1]
3"	3.500 [89]	3"	3.00 [76]	550kcmil(.855 DIA)	750 Kcmil(.998 DIA)	300mm ² STR[22.6]	400mm ² STR[26.1]	GD2039	1.88 [48]	5/8" [16]	2.31 [59]	5.31 [130]	4.13 [101]	---	660 [74.4]
3"	3.500 [89]	3"	3.00 [76]	800 kcmil(1.031 DIA)	1000 Kcmil(1.152 DIA)	400mm ² STR[26.1]	500mm ² STR[28.3]	GD2044	2.00 [51]	5/8" [16]	2.31 [59]	5.31 [130]	4.25 [104]	---	660 [74.4]
3 1/2"	4.000 [102]	3 1/2"	3.50 [89]	#8 SOL(.129 DIA)	#4 STR(.232 DIA)	10mm ² SOL[2.6]	16mm ² STR[5.1]	GD214C	1.44 [37]	3/8" [10]	2.31 [59]	5.31 [130]	3.75 [92]	264	240 [27.0]
3 1/2"	4.000 [102]	3 1/2"	3.50 [89]	#4 SOL(.204 DIA)	2/0 STR(.416 DIA)	25mm ² STR[6.5]	50mm ² STR[9.3]	GD2126	1.50 [38]	3/8" [10]	2.31 [59]	5.31 [130]	3.75 [92]	264	240 [27.0]
3 1/2"	4.000 [102]	3 1/2"	3.50 [89]	2/0 SOL(.365 DIA)	250 Kcmil(.575 DIA)	70mm ² STR[10.9]	120mm ² STR[14.4]	GD2129	1.50 [38]	3/8" [10]	2.31 [59]	5.31 [130]	3.75 [92]	264	240 [27.0]
3 1/2"	4.000 [102]	3 1/2"	3.50 [89]	300 kcmil(.630 DIA)	500 Kcmil(.814 DIA)	185mm ² STR[17.8]	240mm ² STR[20.3]	GD2134	1.56 [40]	1/2" [13]	3.13 [80]	5.69 [139]	3.25 [80]	436	480 [54.1]
3 1/2"	4.000 [102]	3 1/2"	3.50 [89]	550kcmil(.855 DIA)	750 Kcmil(.998 DIA)	300mm ² STR[22.6]	400mm ² STR[26.1]	GD2139	1.88 [48]	5/8" [16]	2.88 [73]	6.06 [148]	4.88 [120]	373	660 [74.4]
3 1/2"	4.000 [102]	3 1/2"	3.50 [89]	800 kcmil(1.031 DIA)	1000 Kcmil(1.152 DIA)	400mm ² STR[26.1]	500mm ² STR[28.3]	GD2144	2.00 [51]	5/8" [16]	2.75 [70]	6.06 [148]	4.88 [120]	373	660 [74.4]
4"	4.500 [114]	4"	4.00 [102]	#8 SOL(.129 DIA)	#4 STR(.232 DIA)	10mm ² SOL[2.6]	16mm ² STR[5.1]	GD224C	1.56 [40]	3/8" [10]	4.19 [106]	5.94 [146]	3.69 [90]	261	240 [27.0]
4"	4.500 [114]	4"	4.00 [102]	#4 SOL(.204 DIA)	2/0 STR(.416 DIA)	25mm ² STR[6.5]	50mm ² STR[9.3]	GD2226	1.63 [41]	3/8" [10]	3.75 [95]	5.81 [142]	3.69 [90]	261	240 [27.0]
4"	4.500 [114]	4"	4.00 [102]	2/0 SOL(.365 DIA)	250 Kcmil(.575 DIA)	70mm ² STR[10.9]	120mm ² STR[14.4]	GD2229	1.63 [41]	3/8" [10]	3.69 [94]	5.81 [142]	3.69 [90]	261	240 [27.0]
4"	4.500 [114]	4"	4.00 [102]	300 kcmil(.630 DIA)	500 Kcmil(.814 DIA)	150mm ² STR[16.0]	240mm ² STR[20.3]	GD2234	1.38 [35]	1/2" [13]	3.31 [84]	6.19 [152]	4.00 [98]	262	480 [54.1]
4"	4.500 [114]	4"	4.00 [102]	550kcmil(.855 DIA)	750 Kcmil(.998 DIA)	300mm ² STR[22.6]	400mm ² STR[26.1]	GD2239	1.88 [48]	5/8" [16]	3.63 [92]	6.56 [161]	4.13 [101]	377	660 [74.4]
4"	4.500 [114]	4"	4.00 [102]	800 kcmil(1.031 DIA)	1000 Kcmil(1.152 DIA)	400mm ² STR[26.1]	500mm ² STR[28.3]	GD2244	2.00 [51]	5/8" [16]	3.25 [83]	6.56 [161]	4.13 [101]	377	660 [74.4]
5"	5.500 [140]	5"	5.00 [127]	#4 SOL(.204 DIA)	2/0 STR(.416 DIA)	25mm ² STR[6.5]	50mm ² STR[9.3]	GD2426	1.75 [44]	1/2" [13]	4.38 [111]	7.25 [184]	4.63 [117]	306	480 [54.1]
1/2" OR 3/4"	.840 OR 1.050 [21] OR [27]	7/8" OR 1"	.875 OR .25 [22] OR [25]	#8 SOL(.129 DIA)	#4 STR(.232 DIA)	10mm ² SOL[2.6]	16mm ² STR[5.1]	GD114C	1.13 [29]	5/8" [16]	3.25 [83]	2.38 [58]	1.75 [43]	222	660 [74.4]
6"	6.625 [168]	--	--	#4 SOL(.204 DIA)	2/0 STR(.416 DIA)	25mm ² STR[6.5]	50mm ² STR[9.3]	GD8626	1.63 [41]	1/2" [13]	6.03 [153]	8.19 [201]	4.31 [106]	275	480 [54.1]
-	-	3/4"	.75 [19]	300 kcmil(.630 DIA)	500 Kcmil(.814 DIA)	150mm ² STR[16.0]	240mm ² STR[20.3]	GD6434	1.56 [40]	1/2" [13]	1.00 [25]	3.59 [88]	3.69 [90]	302	480 [54.1]
6"	6.625 [168]	--	--	2/0 SOL(.365 DIA)	250 Kcmil(.575 DIA)	70mm ² STR[10.9]	120mm ² STR[14.4]	GD8629	1.63 [41]	1/2" [13]	5.81 [148]	8.31 [211]	4.31 [106]	275	480 [54.1]

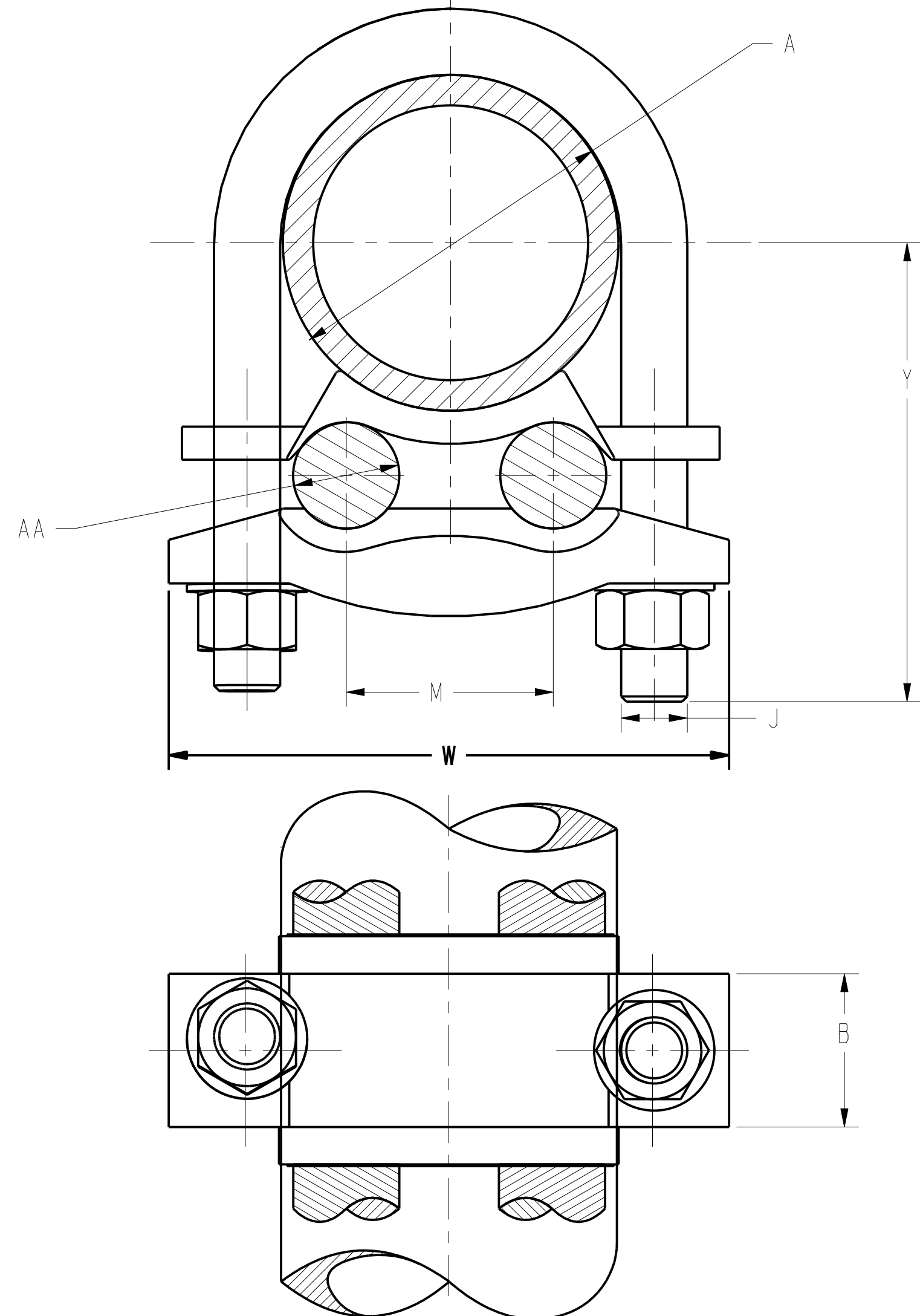

- NOTES:
1. MATERIAL : CAST COPPER ALLOY, DURIUM #6 (U-BOLT, HEX NUTS & S.P.L.W).
 2. UL 467 LISTED, FILE NO. E9999. ACCEPTABLE FOR DIRECT BURIAL.
 3. SUITABLE FOR BURIAL IN GROUND OR CONCRETE.
 4. DIMENSIONS IN BRACKETS [] ARE IN MILLIMETERS, ROUNDED OFF TO THE NEAREST MILLIMETER, UNLESS OTHERWISE NOTED, AND ARE FOR REFERENCE ONLY.
 5. FOR TIN PLATING ADD SUFFIX "TN".

TO ORDER BURNDY® PRODUCTS CALL		GROUND CONNECTOR	
UNITED STATES		ITEM NO: SEE TABLE	
1-800-346-4175 (LONDONDERRY, NH)		CAT. NO: GD--(TABLE)	
CANADA:		DRAWN BY: R PERREAULT 5/24/94	
1-800-361-6975 (QUEBEC)		CHECKER: --	
1-800-387-6487 (ALL OTHER PROVINCES)		DSN APPVL: G DITROIA 11/11/93	
FOR PRODUCT INFO: http://www.burndy.com		MFG APPVL: --	
		QA APPVL: A LLOYD 12/3/93	
		MKT APPVL: K WOO 11/11/93	
		PROD FAM: --	
		PROJECT #: FPN1506071	SIZE
		DOCUMENT TYPE: Sales	D
		REL LEVEL: Released	
		DRAWING NO	REV
		SD013775	E
		SHEET 2 OF 2	

REV: PE0200